



특징 (Character)

- 랙 & 피니언(단, AF13-20은 링크 & 레버 타입)
Rack & Pinion type (AF13-20 is Link & Lever type)
- 바디와 가이드 로드예 의한 2중지지 방식의 견고성
Strength of double support by body and guide rod
- 다양한 기종으로 폭넓은 선택이 가능
Wide and various selection possible by various size
- 3방향 취부로 다양한 방법의 취부가 가능
Mounting possible from 3 sides
- 개폐검출 센서 전기종 부착가능
Magnetic sensor is available for open-close sensing



랙 & 피니언 방식 (Rack & Pinion type)

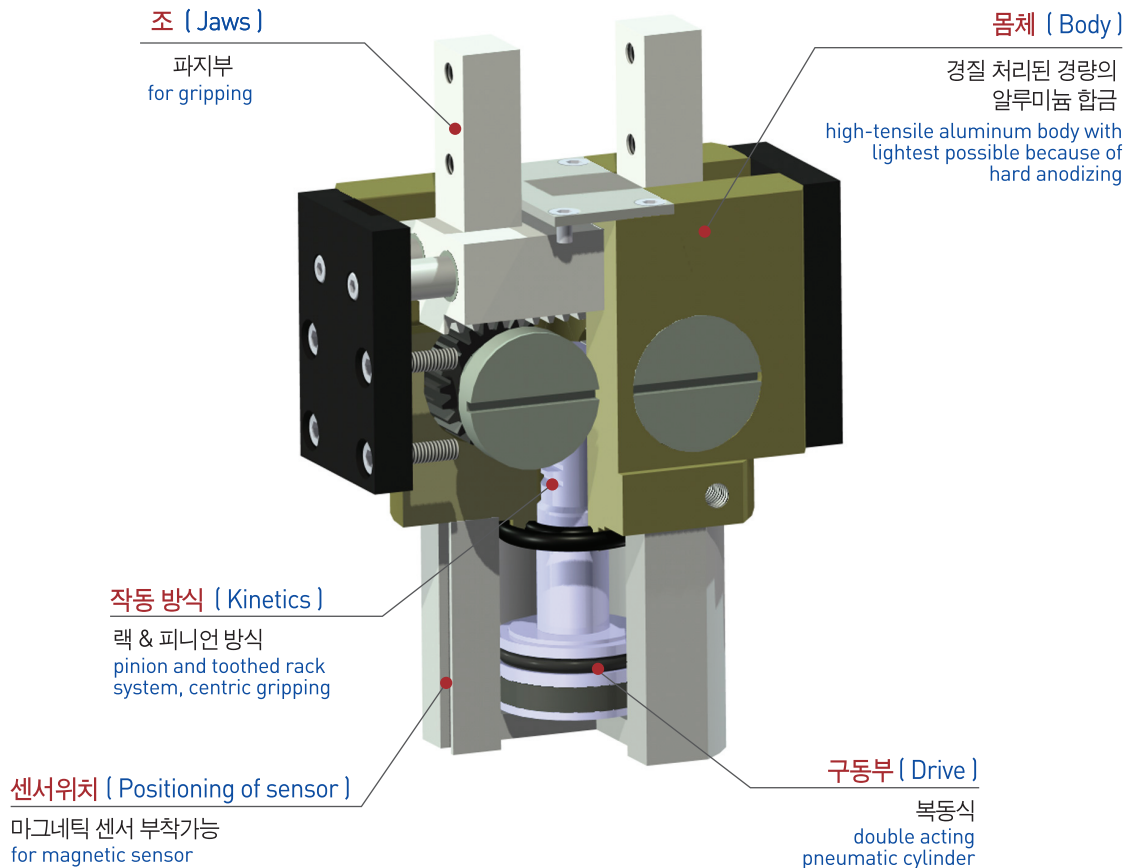

부품분해도 (Exploded view)

※ 본 분해도는 한 제품을 예시하였으므로 기종별로 차이가 있을 수 있습니다
 ※ This exploded view illustrates a certain product only. The contents may vary by product models.

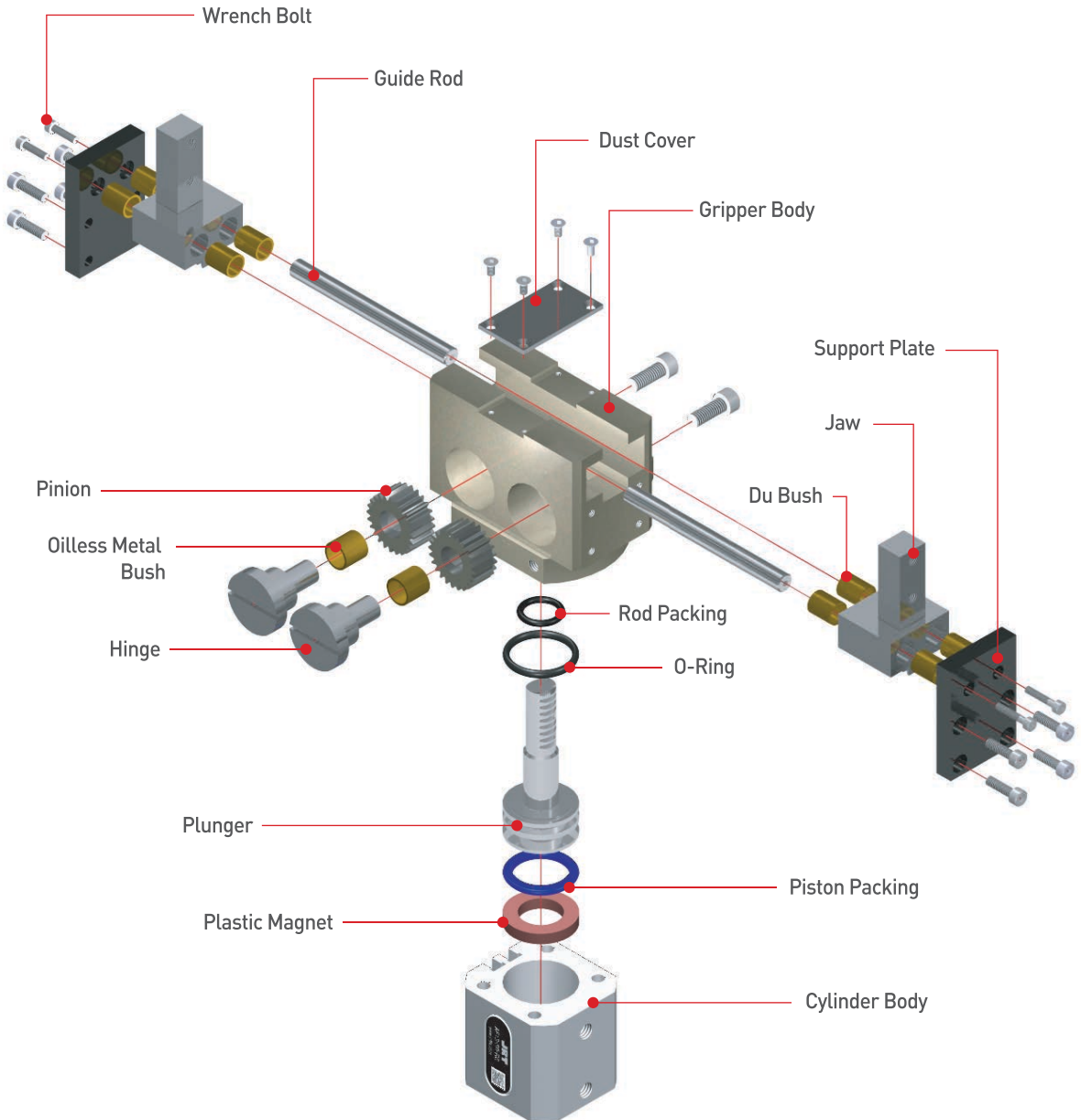

AF101
AF02
AF03
AF04P
AF105P
AF06
AF10
AF13
AF13C
AF14
AF15
AF316
AF17
AF117
AF19
AF24
AF26
AF28D
AF30
AF30L
AF30SP
AF40
AF46
AF56N
RAF56N
MF16

주문기호 (Ordering Code)

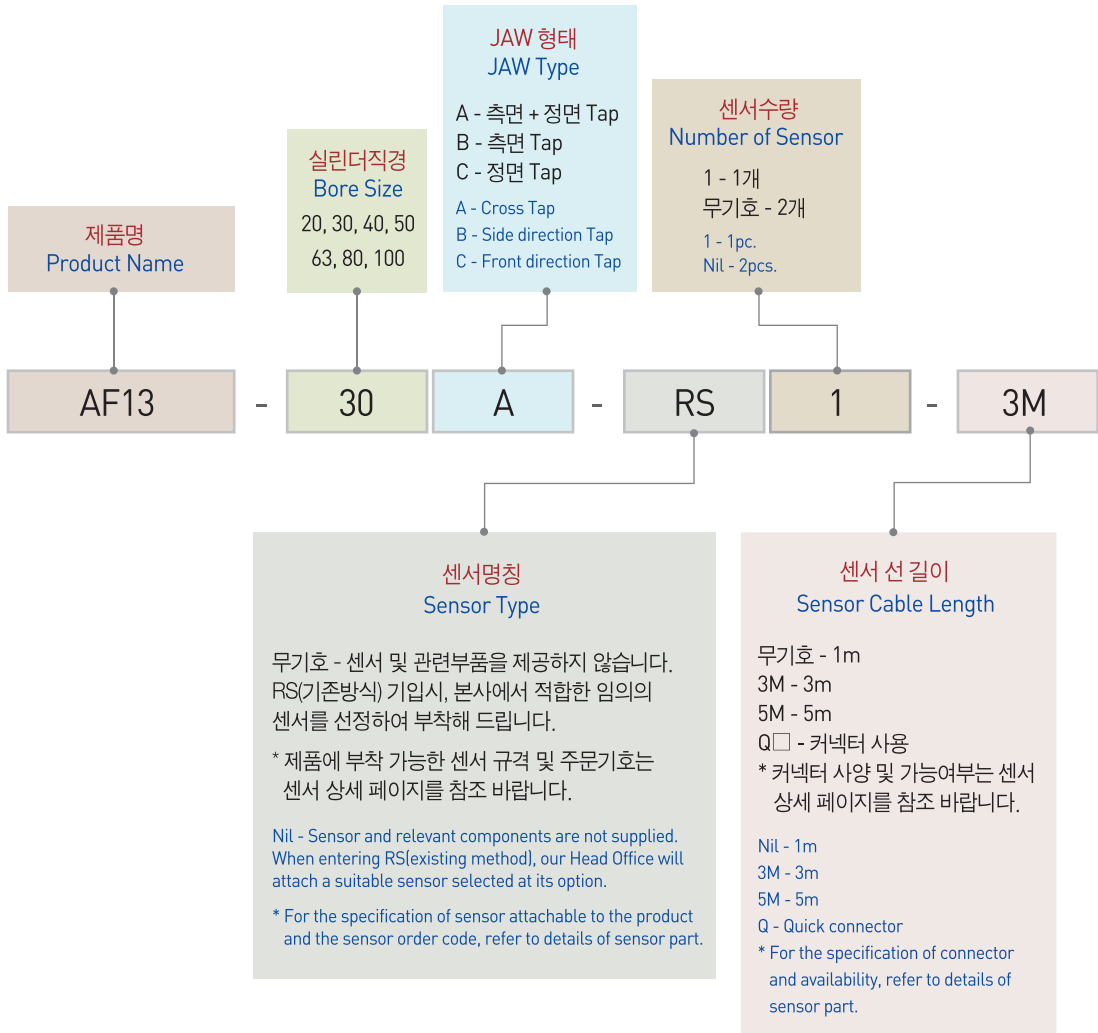

☞ 제품사양 (Specification)

P=공기압력(bar) , L=작용점까지의 거리(mm)
P=Air Pressure(bar) , L=Exertion length(mm)

제품명칭 Products Name	AF13-20	AF13-30	AF13-40	단위 Unit
개폐범위 Stroke	12	24	30	mm
제품중량 Weight	0.55	1.3	2.2	kg
최대치구길이 Max. length attach	70	90	110	mm
배관접속구 Fitting size	M5	PF(G) 1/8	PF(G) 1/8	
파지력 : 열림시 Gripping force : Open	24.53P/(1+0.025L)	55.92P/(1+0.02L)	98.10P/(1+0.02L)	N
파지력 : 닫힘시 Gripping force : Close	19.62P/(1+0.025L)	48.07P/(1+0.02L)	83.39P/(1+0.02L)	N
1사이클당 공기소모량 Air consumption per cycle	3.3	15.1	33.9	cm ³
닫힘시/열림시 시간 Closing / Opening time	0.01/0.01	0.01/0.01	0.01/0.02	sec
반복정밀도 Repeat accuracy	0.03			mm
연속사용회수 Continuation usage amount	60			cpm
사용압력 Operating pressure	3~7			bar
주위온도 Ambient temperature	-5 to 60			℃
윤활 Lubrication	불필요 Needless			

제품명칭 Products Name	AF13-50	AF13-63	AF13-80	AF13-100	단위 Unit
개폐범위 Stroke	36	40	50	60	mm
제품중량 Weight	3.35	5.03	8.29	12.7	kg
최대치구길이 Max. length attach	130	140	150	200	mm
배관접속구 Fitting size	PF(G) 1/8	PF(G) 1/8	PF(G) 1/4	PF(G) 1/4	
파지력 : 열림시 Gripping force : Open	154.02P/(1+0.015L)	242.31P/(1+0.012L)	395.34P/(1+0.01L)	654.33P/(1+0.01L)	N
파지력 : 닫힘시 Gripping force : Close	137.34P/(1+0.015L)	210.92P/(1+0.012L)	350.22P/(1+0.01L)	595.47P/(1+0.01L)	N
1사이클당 공기소모량 Air consumption per cycle	65.0	114.9	235.9	450.0	cm ³
닫힘시/열림시 시간 Closing / Opening time	0.03/0.04	0.05/0.06	0.11/0.12	0.22/0.23	sec
반복정밀도 Repeat accuracy	0.03				mm
연속사용회수 Continuation usage amount	40	30	30	20	cpm
사용압력 Operating pressure	3~7				bar
주위온도 Ambient temperature	-5 to 60				℃
윤활 Lubrication	불필요 Needless				

반복정밀도 : 연속 100회 작동후 측정치
After 100 consecutive strokes to end position

- AF101
- AF02
- AF03
- AF04P
- AF105P
- AF06
- AF10
- AF13**
- AF13C
- AF14
- AF15
- AF316
- AF17
- AF117
- AF19
- AF24
- AF26
- AF28D
- AF30
- AF30L
- AF30SP
- AF40
- AF46
- AF56N
- RAF56N
- MF16

작용점에서의 파지력 (Gripping Force From a Point of Action)

범례(legend) : 7[bar] 5[bar] 3[bar]

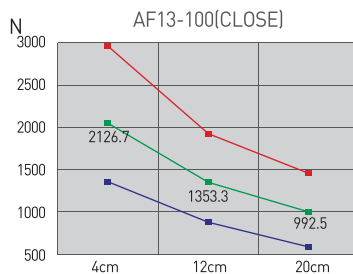
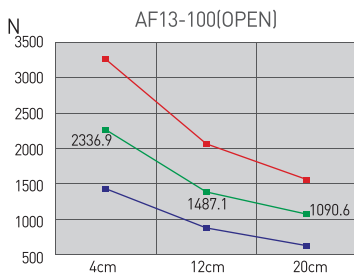
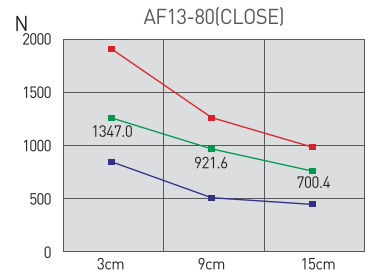
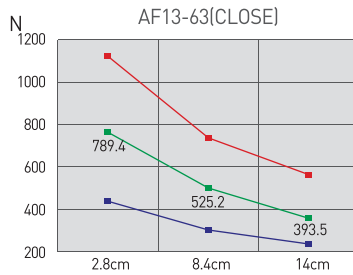
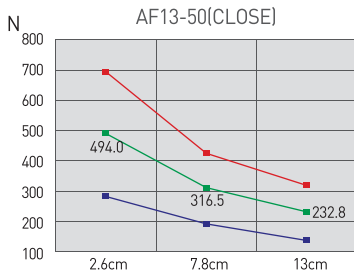
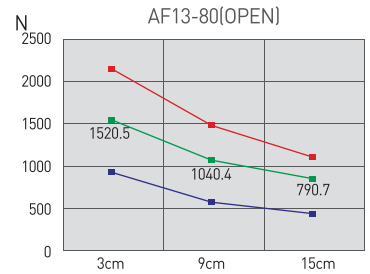
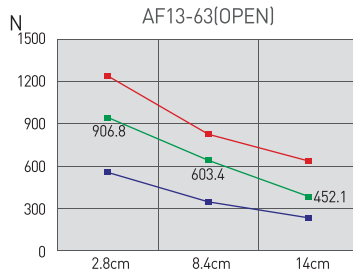
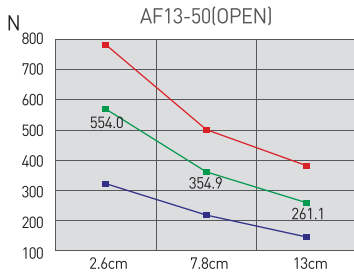
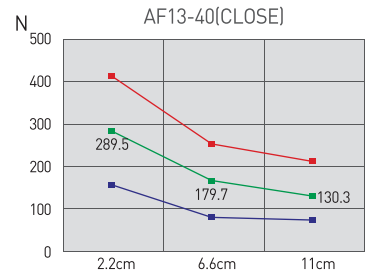
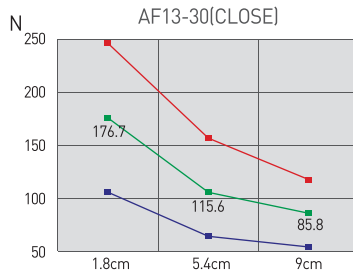
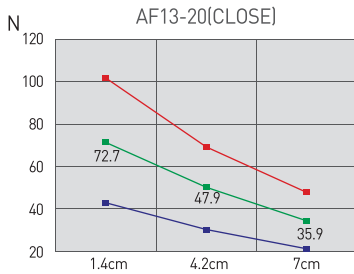
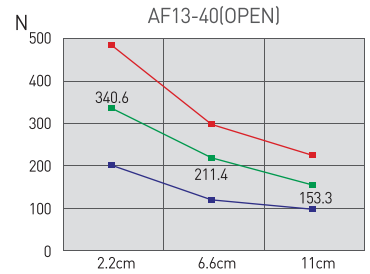
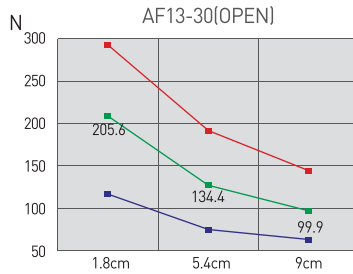
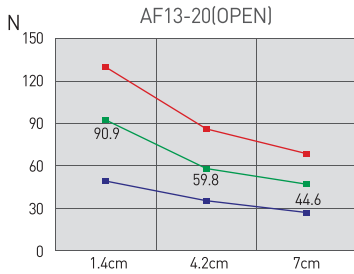

AF13-20

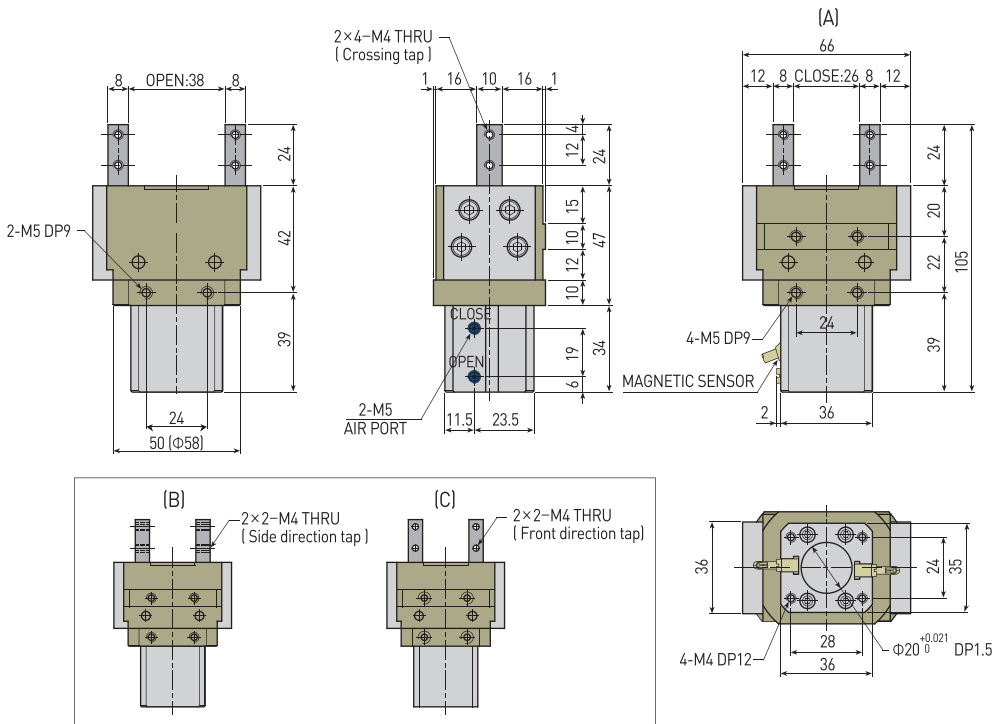

AF13-30

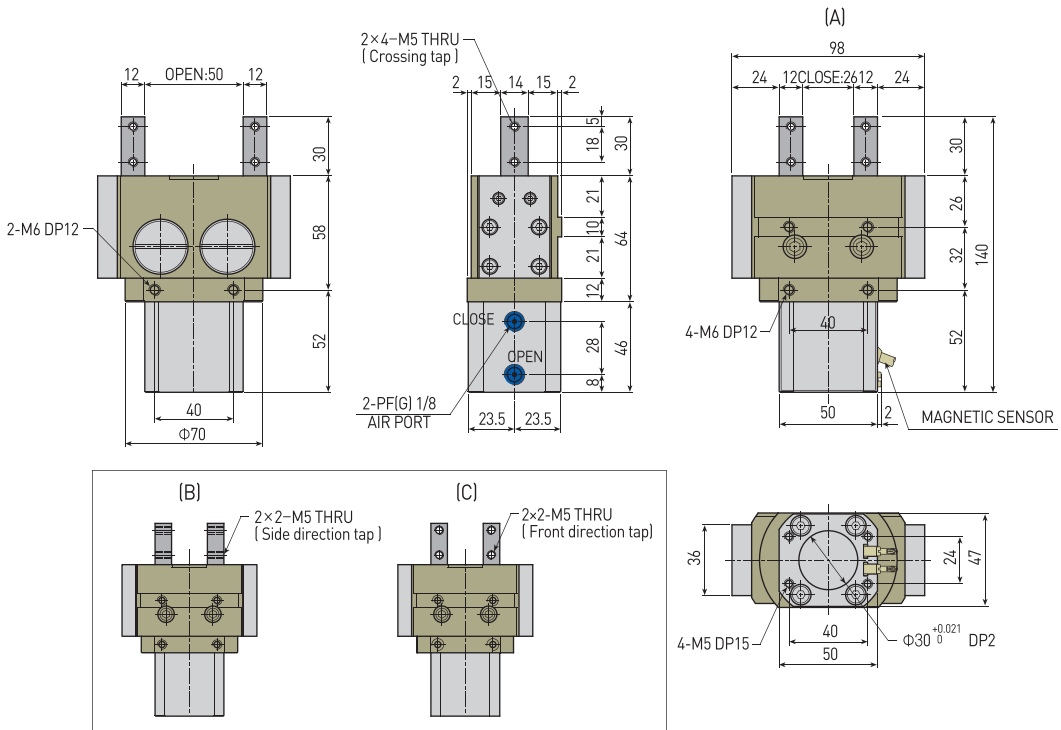

- AF101
- AF02
- AF03
- AF04P
- AF105P
- AF06
- AF10
- AF13**
- AF13C
- AF14
- AF15
- AF316
- AF17
- AF117
- AF19
- AF24
- AF26
- AF28D
- AF30
- AF30L
- AF30SP
- AF40
- AF46
- AF56N
- RAF56N
- MF16

AF13-40

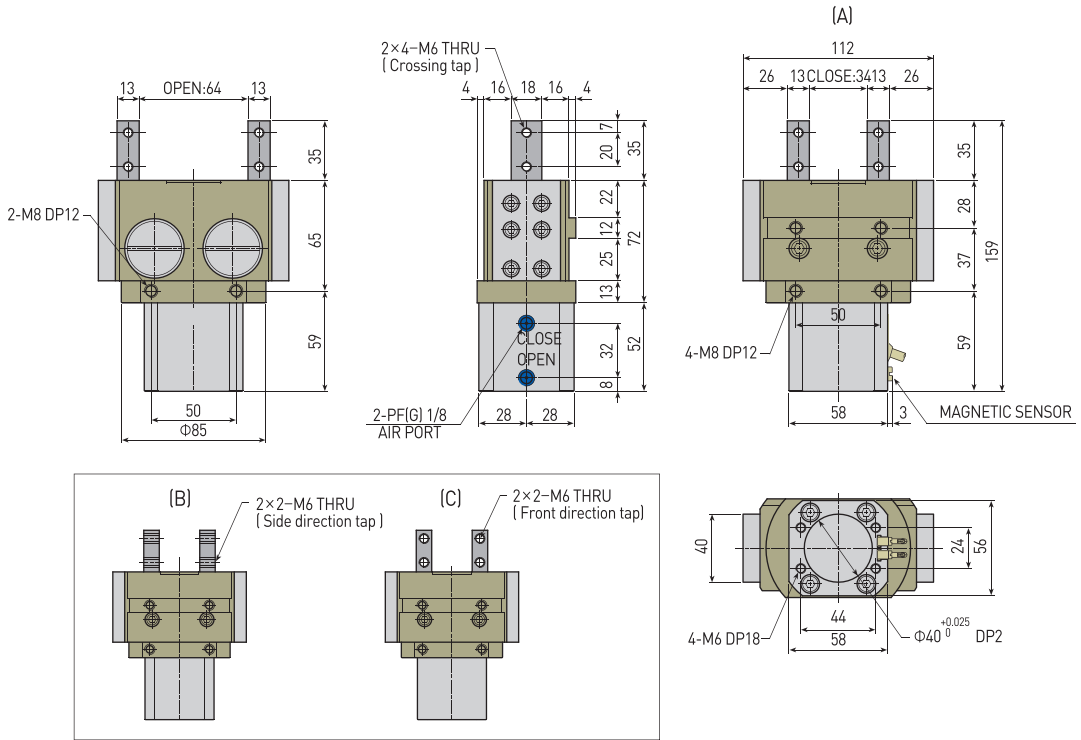

AF13-50

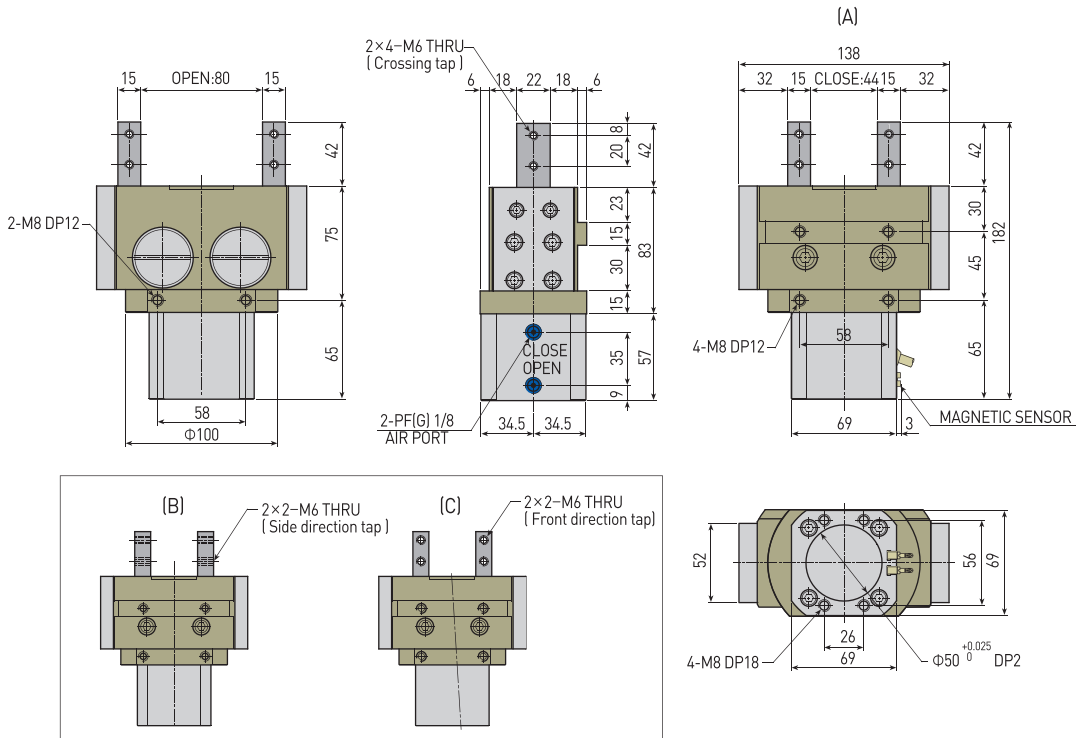

AF13-63

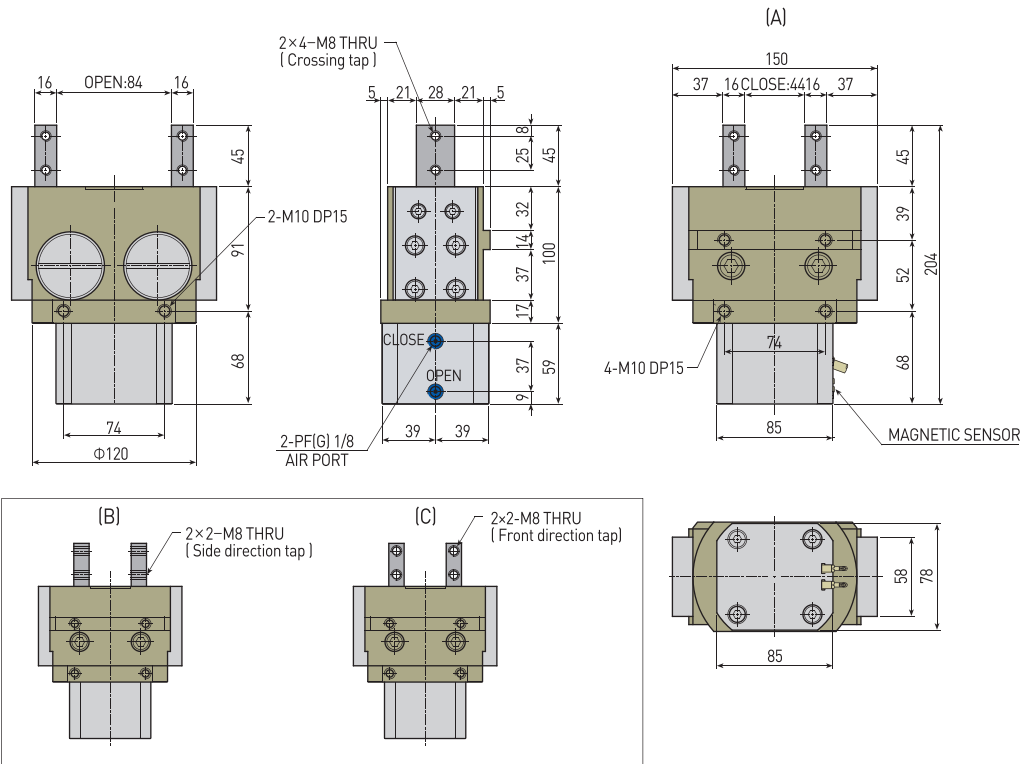

- AF101
- AF02
- AF03
- AF04P
- AF105P
- AF06
- AF10
- AF13**
- AF13C
- AF14
- AF15
- AF316
- AF17
- AF117
- AF19
- AF24
- AF26
- AF28D
- AF30
- AF30L
- AF30SP
- AF40
- AF46
- AF56N
- RAF56N
- MF16

AF13-80

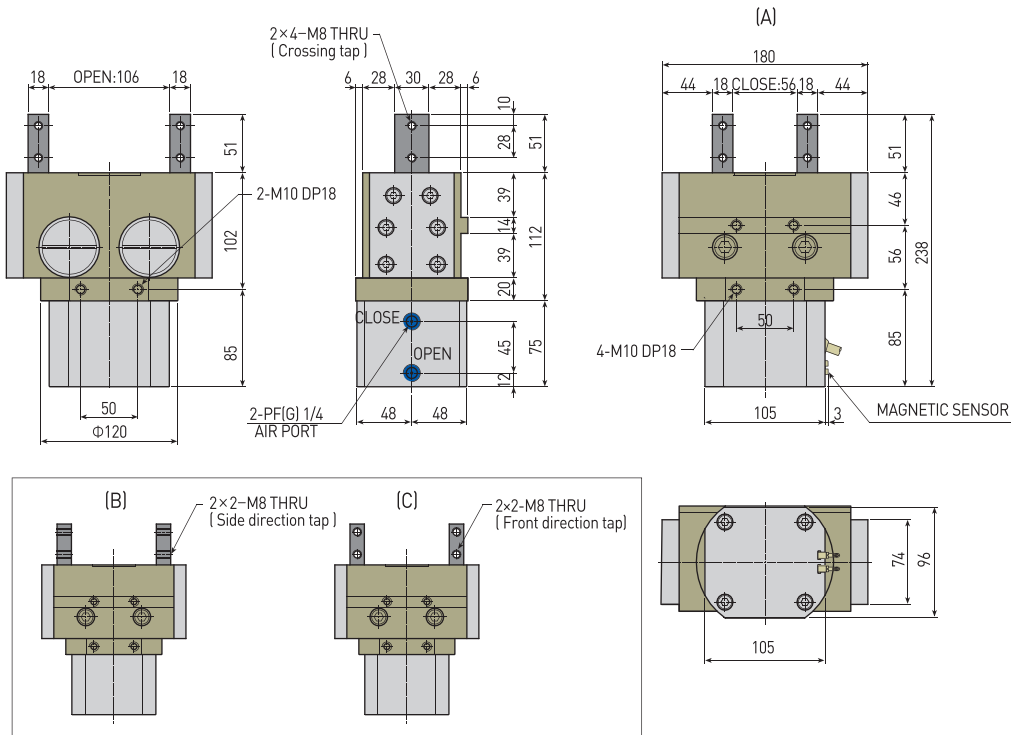

AF13-100

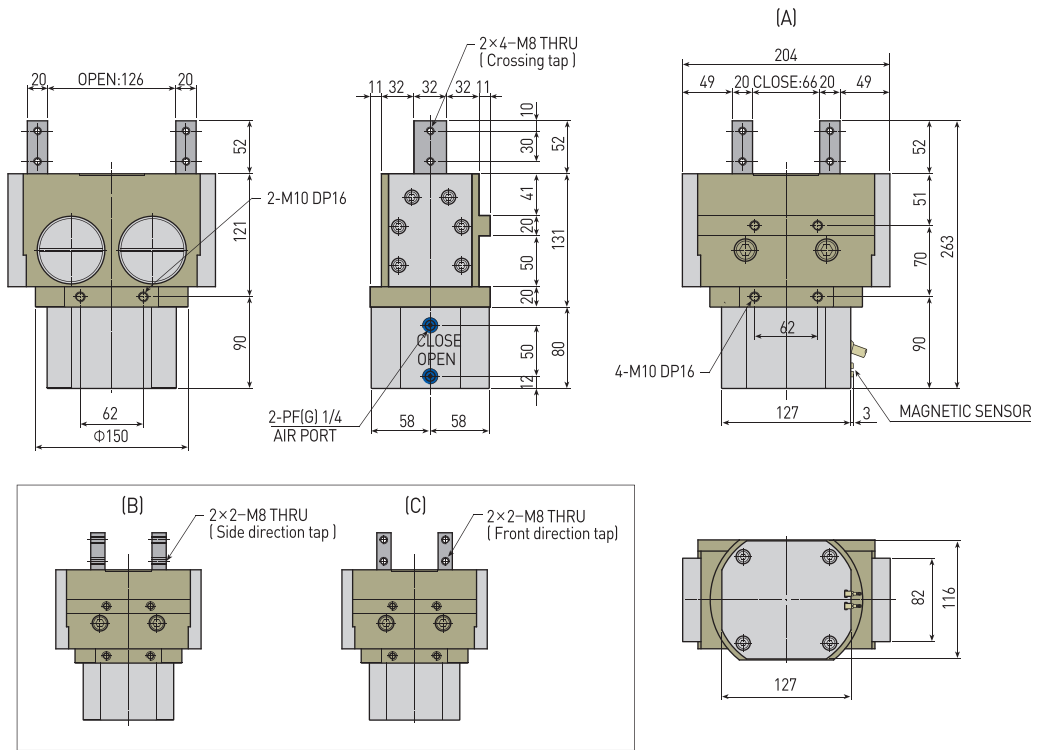

NOTE